



FLEXANTENNA – Floor Mount Kit

SUPERIOR SCANNING

FLEXANTENNA offers best-in-class tag read performance across tag orientations. Focused linear antennas reduce cross reads and blind spots. Install individual units or combine multiple units as needed.

FLEXIBLE INSTALLATION

Contractors can install floor mounts in advance of bringing FLEXANTENNA units on site. Keep concrete dust and debris separate from portal installation for faster installations. Set screws allow for leveling on uneven surfaces to ensure best performance.

EASE OF DEPLOYMENT

With rising costs of shipping and labor, FLEXANTENNA is a clear winner with reduced costs to transport, deploy, and support. The modular design reduces size and weight allowing for standard parcel shipments and single person installation.



Floor Mount Kit Contents:



(4) 5/8" length 3/8"-16 hex screws



(4) 3/8" flat washers



(4) 3/8" leveling set screws



(4) 3" length 3/8" concrete anchors



(1) FLEXANTENNA FLOOR PLATE

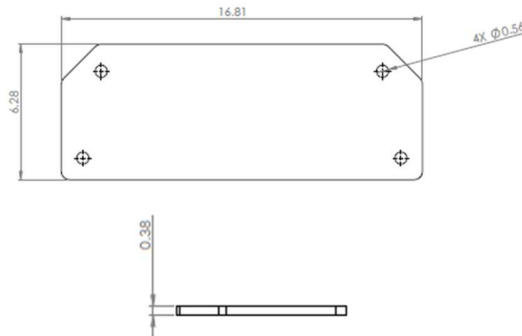

FLOOR MOUNT SPECIFICATIONS

Dimensions: 16.81" x 6.28" x 0.38"

Weight: 3.5 lbs

Material: Aluminum

Finishing: RAL 1023 Safety Yellow

FLEXANTENNA FLOOR MOUNT KIT FEATURES:

- Set screws enable leveling on uneven surfaces
- Install from either end of FLEXANTENNA unit
- Install before or after FLEXANTENNA mounting
- Sturdy hardware for industrial applications

© 2024 RFIDKNOW LLC
775 Woodruff Road Suite H Greenville, SC 29607
+1 (864) 881 – 2282
info@rfidknow.com
www.rfidknow.com

